

Technology Art Sound
Manufactured by
elettromeia italy



ML Power

ADVANCED **WEB MANUAL**

ML Power 4
rev 1.0c

The User Manual is also
available from our web site
www.hertzaudiovideo.com

www.hertzaudiovideo.com

HERTZ
The Sound Experience

Index

1. INTRODUCTION	3
2. PACKAGE CONTENTS	3
3. SAFE SOUND	4
4. GENERAL PRECAUTIONS	5
5. INSTALLATION AND SIZE	6
6. BATTERY / REMOTE CONNECTION AND HOW TO REPLACE THE FUSE	7
7. AUTO TURN-ON WITH HI-LEVEL INPUTS	7
8. TOP PANEL CONTROLS: SWITCHES AND ADJUSTMENT	8
9. FRONT AND REAR PANELS	9
10. CONFIGURATION DIAGRAMS	
PRE-IN A FOR WOOFER AND MID/HI	10
PRE-IN A/B FOR FRONT AND REAR	11
PRE-IN A AND HI-IN B FOR FRONT AND REAR	12
HI-IN A AND PRE-OUT	13
HI-IN A AND B AND PRE-OUT	14
HI-IN A AND B FOR FRONT AND REAR	15
PRE-IN A FOR FRONT AND SUBWOOFER MONO (BRIDGE)	16
PRE-IN A AND B FOR FRONT DUAL MONO	17
HI-IN A AND PRE-OUT FOR WOOFER AND MID/HI	18
11. CABLES	19
12. BLOCK DIAGRAM	20
13. TECHNICAL SPECIFICATIONS	21

1 INTRODUCTION

Thank you for purchasing a Hertz product, designed according to the highest quality standards.





Your ML Power amplifier is a cutting-edge product of compact size, providing high power and quality of sound.

It will definitely ensure you maximum satisfaction by taking up very small room in your vehicle.

Before the installation, in addition to reading the Quick Start Guide (QSG), the consultation of this user's manual available on the Hertz website will let you achieve the highest performance from your amplifier.

2. PACKAGE CONTENTS

In the package, besides your amplifier, you will find:

- **Quick Start Guide** 
- **Warranty Card** 
- **40 A blade fuse**  x2
- **4,2 x 16 mm self-tapping, cross-headed fixing screws**  x4

3. SAFE SOUND

HERTZ AMPLIFIERS CAN BE PART OF A HIGH POWER AUDIO SYSTEM THAT CAN GENERATE VERY HIGH UNDISTORTED SOUND PRESSURE LEVELS. PLEASE REMEMBER THAT LONG EXPOSURE TO AN EXCESSIVELY HIGH SOUND PRESSURE LEVEL MAY DAMAGE YOUR HEARING; THEREFORE, PLEASE USE COMMON SENSE AND PRACTICE SAFE SOUND.

Safety must be at the forefront while driving. The listening volume should never obscure the noise coming from the outside of your vehicle; you should be able to hear the sounds generated by your vehicle in order to promptly face any emergency situation.

To achieve the best possible performance from your new components, we recommend you follow the instructions in this manual carefully. In order to design and create top level car hi-fi systems you need to understand automobile mechanical and electrical issues very well; if you think you lack the required knowledge or the proper tools, please consult with a specialized installer.

A professional installation will ensure your system delivers all the performance you have paid for, without affecting the safety and reliability of your vehicle.

This manual has been designed to provide you with the basic instructions required to install and use this product. However, the range of possible applications is very wide; to obtain further information, please contact your authorized Hertz dealer or Hertz service center.

You can also send an e-mail directly to the following addresses:

Italy - supporto.tecnico@elettromedia.it

Worldwide - support@elettromedia.it

4. GENERAL PRECAUTIONS

- This symbol indicates that you have to pay attention to these instructions. Disregarding them might cause accidental harms or damage your amplifier.
- Before installing the amplifier, make sure you carefully read and understand all instructions.
- The vehicle electric system must have 12V DC voltage with negative to ground. Make sure your car has it in order to avoid any damages to your amplifier and to the vehicle.
- Pre-plan the configuration of your new amplifier and the best wiring routes to ease installation.
- Always wear protective eyewear when using tools that may generate splinters.
- During installation, keep the amplifier in its packing as long as possible; this will protect it from damages.
- Secure all auxiliary devices you built to install the components to the vehicle structure through brackets, screws, nuts and bolts; this insures stability and safety while driving.
- The amplifier detachment while driving can damage the people in the vehicle and other cars. Secure the amplifier at best, paying utmost attention if installation is inside the passenger's compartment. Do not carry out any installation inside the engine compartment.
- Before installing the amplifier, turn off the source and all other electronic devices in the audio system for preventing any damages.
- Make sure the location you chose for the components does not affect the correct functioning of the vehicle mechanic and electric devices.
- Do not run the cables or install the amplifier next to electronic gearcases.
- Use extreme caution when cutting or drilling the car plate, checking there are no electrical wiring or structural element underneath.
- Before connecting the power cable to the amplifier, disconnect the negative lead (-) from the car battery.
- Make sure power cable is not short circuited during installation and connection.
- Power cable must have mechanically resistant and self-extinguishing insulation. Its section have a size corresponding with what is suggested in this manual. Avoid to run it over or through sharp edges or close to moving mechanical devices. Make sure it is well fixed all along its length. Block positive and negative cables just close to the amplifier respective power supply terminal blocks through a clamping screw.
- Use rubber grommets to protect the wire if it runs in a hole of the plate or proper materials if it is close to heat-generating parts.
- To ground the device (-) in the right way, use a screw in the vehicle chassis; scrape all paint or grease from the metal if necessary, checking with a tester that there is continuity between the battery negative terminal (-) and the fixing point. If possible, connect all components to the same ground point; this solution rejects most noise.
- Route all signal cables away from power cables.
- Never run cables outside the vehicle; you would not be protected against wear and in case of accidents.
- When installing speakers and the cables that connect them, make sure that non-insulated parts never touch, even occasionally, the vehicle cutting parts. If they do, the amplifier protection is activated.
- To prevent all problems, use very good quality cables, connectors and accessories, choosing them in Connection catalogue.
- When installation is over, and before plugging the main power supply fuse, check the system wiring and make sure all connections were done in the right way.
- Power amplifiers put an increased load on the battery and on its charging system. We recommend checking your alternator and battery condition to ensure they can handle the increased consumption. Standard electrical systems which are in good condition should be able to stand this extra load without problems but we recommend the use of an energy storage capacitor and/or a battery for high level audio systems.
- Put a fuse and its insulated fuse holder 40 cm max. far from the battery positive terminal; connect one end of the power cable to it after connecting the other end to the amplifier. The fuse value must be 50% higher than the amplifier built-in one. In case the cable supplies several amplifiers, the fuse value will have to be 50% higher than the sum of the values of all other fuses in the amplifiers.
- There must be good air circulation where the amplifier is installed; this area must not be affected by humidity, rain, external deposits or parts coming from the vehicle mechanical devices. Do not hinder in any way the cooling of the amplifier side fins
- Install the amplifier in the vehicle parts where temperature is between 0°C (32°F) and 55°C (131°F).



WARNING: When working in demanding conditions, the amplifier can reach temperatures of around 80 - 90°C (176- 194°F). Make sure it is not dangerously hot before touching it.

- Periodically clean the amplifier without using aggressive solvents that might damage it. Dampen a piece of cloth with water and soap, wring it and clean the amplifier. Then use a piece of cloth dampened with water only; eventually clean the amplifier with a dry piece of cloth.
- Remove dust and solid deposits from the heat sink side fins. Don't use compressed air on the amplifier since it would push solid parts in the amplifiers. If necessary, please contact a specialised service centre for internal cleaning. Cooling system obstruction makes the amplifier go in safety mode.

5. INSTALLATION AND SIZES

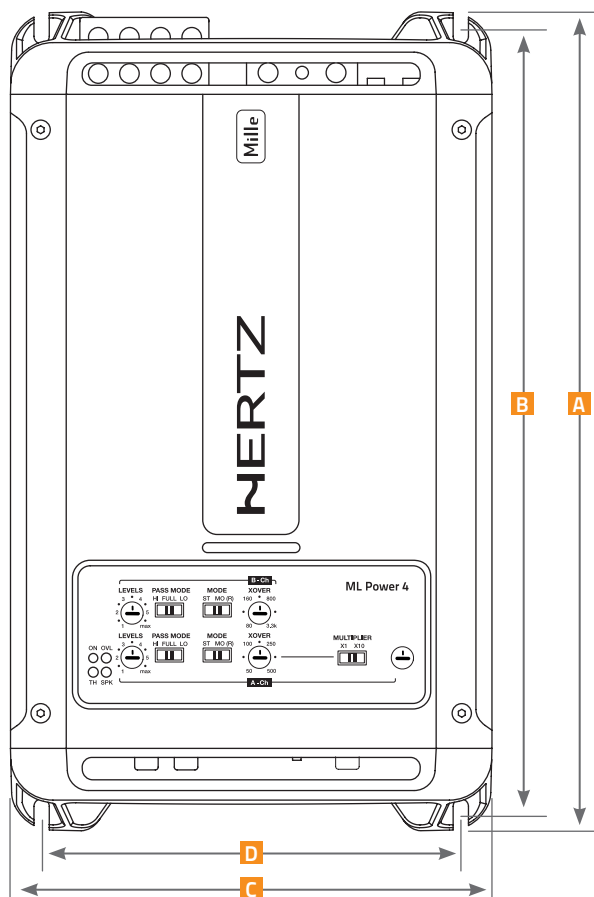

	A	B	C	D	E	
ML Power 4	289	272	170	148	46,7	mm
	11.38	10.71	6.69	5.83	1.84	in.

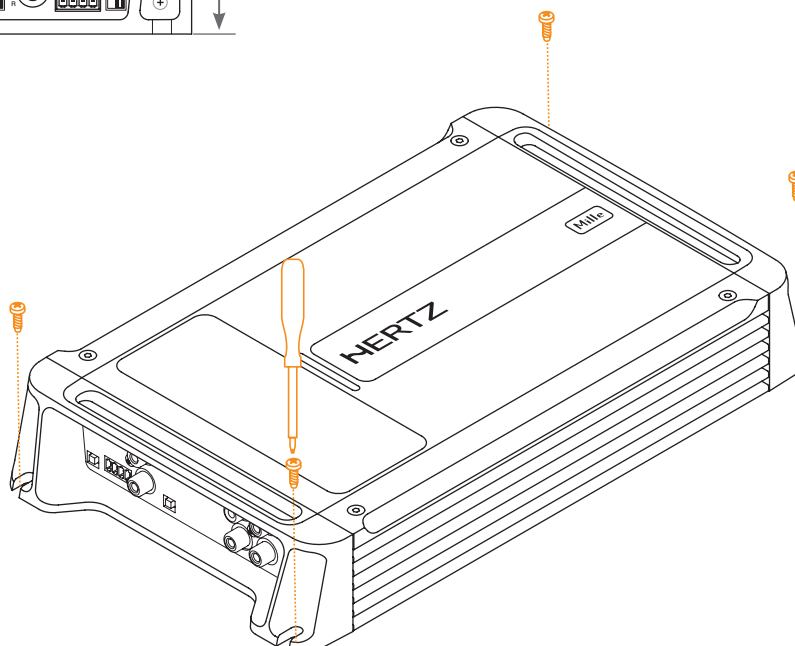
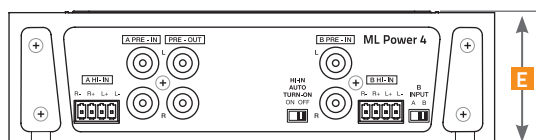

6. BATTERY / REMOTE CONNECTION AND HOW TO REPLACE THE FUSE

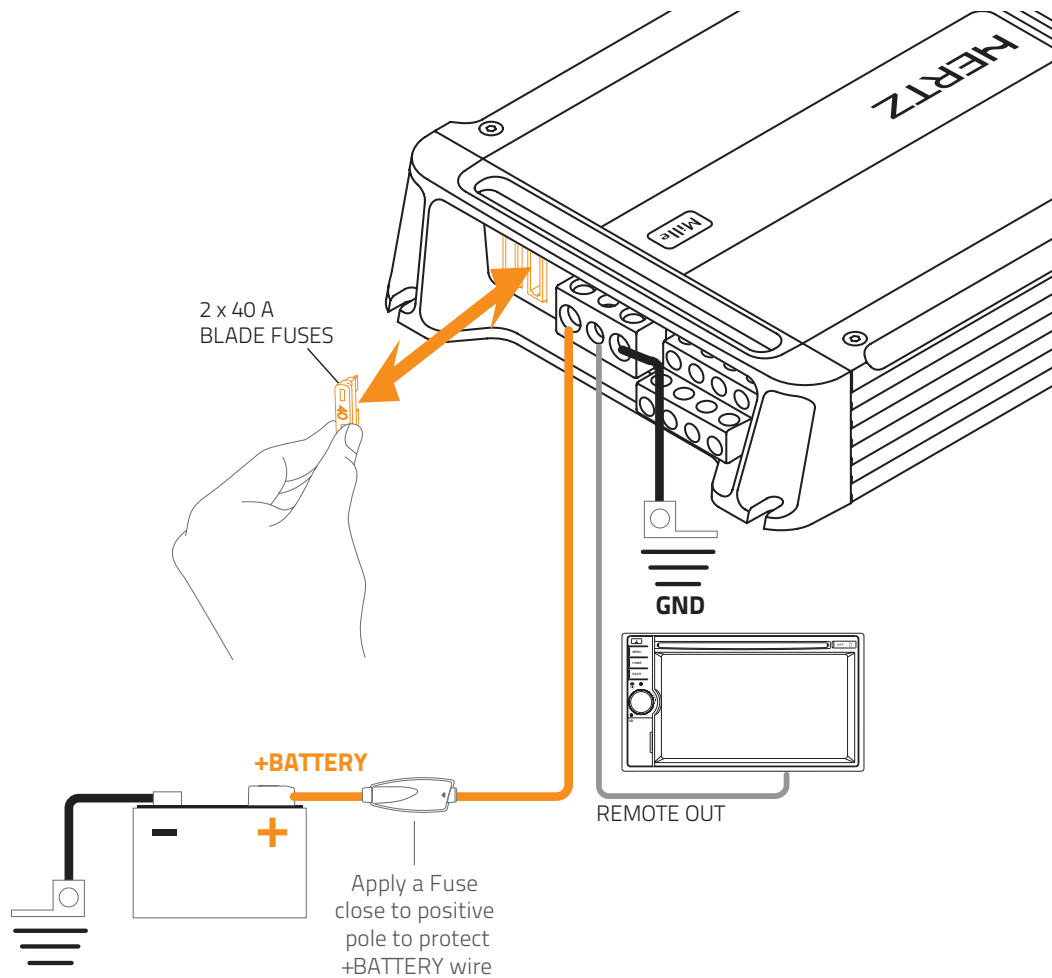

7. AUTO TURN-ON WITH HI-LEVEL INPUTS

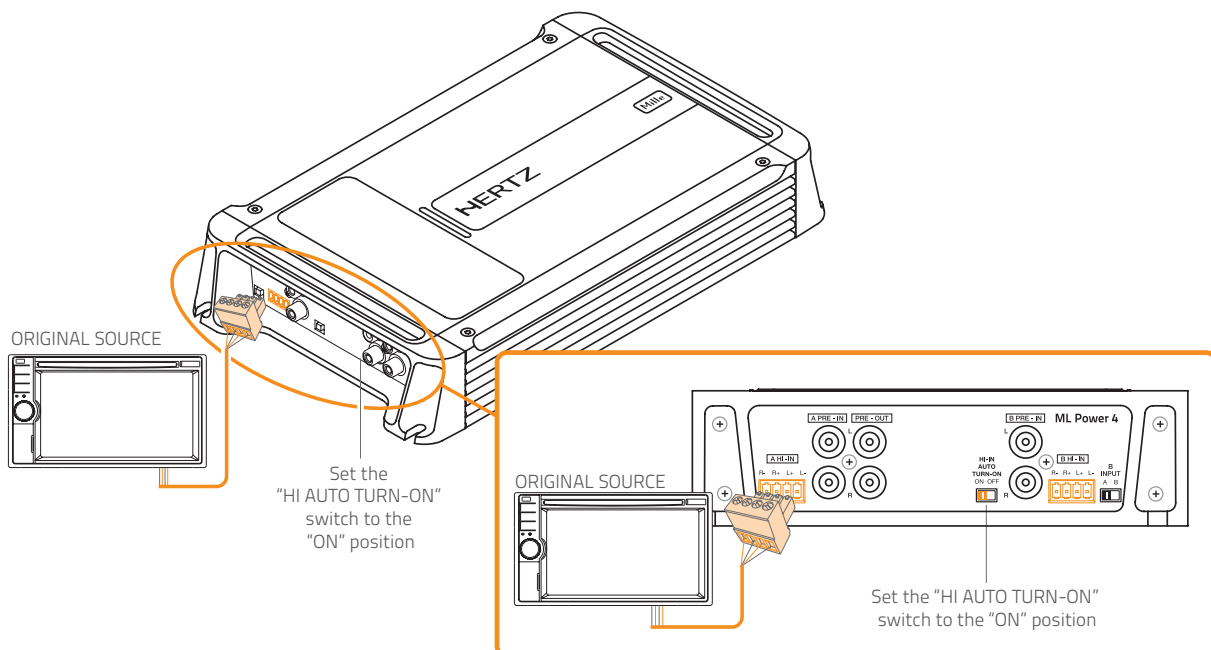

8. TOP PANEL CONTROLS: SWITCHES AND ADJUSTMENT CONTROLS

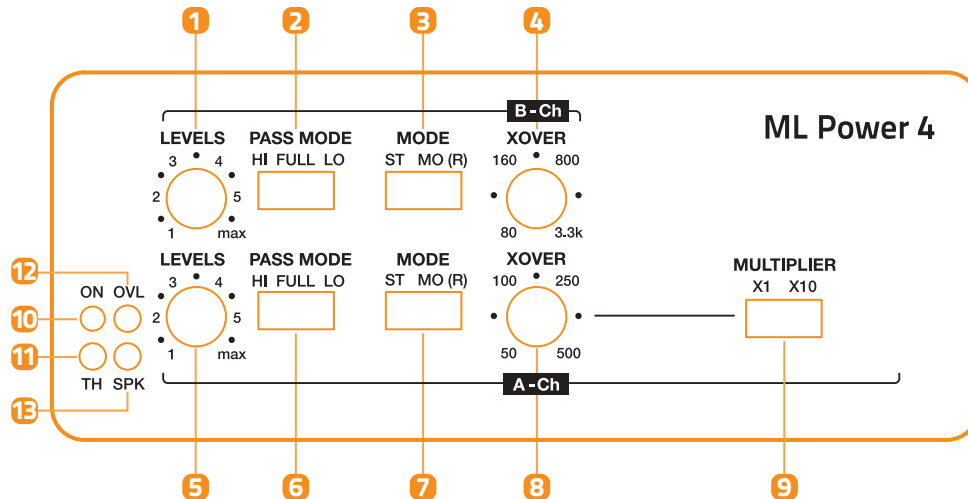

- 1 B CH LEVELS: B channels input sensitivity adjustment control.** Set to 1 position. Use a CD as source, increase head unit volume until output distorts, then decrease volume by 1 step in order to eliminate distortion. Turn LEVELS up until sound becomes distorted, then turn LEVELS down a bit for optimum sound.
- 2 PASS MODE (HI - FULL - LO): B channels filter switch.** Select FULL to drive full range power outputs. The full frequency bandwidth will be output to power output connectors. Select HI for Hi-pass to drive a MIDRANGE / TWEETER. Select LO for Lo-pass to drive a SUB / WOOFER / MIDRANGE.
- 3 MODE (ST - MO(R)): Select ST to set B channels to stereo mode.** Left and Right input signals drive Left and Right power outputs. Select MO(R) for mono (bridge) operation. With this setup the Right input channel drives BR and BL power output, so connect loudspeaker to BL- and BR+ for proper bridge connection.
- 4 XOVER (80 Hz + 3.3 kHz): B channels crossover point adjustment.** Rotating the knob you can select any frequencies between 80 Hz and 3.3 kHz. The frequencies above crossover point will be attenuated at 12dB/Oct.
- 5 A CH LEVELS: A channels input sensitivity adjustment control.** Set to 1 position. Use a CD as source, increase head unit volume until output distorts, then decrease volume by 1 step in order to eliminate distortion. Turn LEVELS up until sound becomes distorted, then turn LEVELS down a bit for optimum sound.
- 6 PASS MODE (HI - FULL - LO): A channels filter switch.** Select FULL to drive full range power outputs. The full frequencies bandwidth will be output to power output connectors. Select HI for Hi-pass to drive a MIDRANGE / TWEETER. Select LO for Lo-pass to drive a SUB / WOOFER / MIDRANGE.
- 7 MODE (ST - MO(R)): Select ST to set A channels to stereo mode.** Left and Right input signals drive Left and Right power outputs. Select MO(R) for mono (bridge) operation. With this setup the Right input channel drives AR and AL power output, so connect loudspeaker to AL- and AR+ for proper bridge connection.
- 8 XOVER (50 Hz + 500 Hz): A channels crossover point adjustment.** Rotating the knob you can select any frequency between 50 Hz and 500 Hz. The frequencies over crossover point will be attenuated at 12dB/Oct.
- 9 MULTIPLIER (x1 - x10): Select X1 for normal frequency range (50 Hz - 500 Hz) of A channel filter (Hi-pass or Lo-pass).** Select X10 for crossover point multiplied by 10 (500 Hz - 5 kHz).
- 10 ON: Power LED.** It lights up when you turn on the amplifier. If all LEDs (10) (11) (12) (13) turn on at the same time, the amplifier will shut down and you will have to contact a service centre.
- 11 TH: Thermal status LED.** It lights up when thermal protection is active, above 85°C. The amplifier shuts down until the chassis temperature goes below 75°C.
- 12 OVL: Overload status LED.** It lights up when overload occurs on the power output terminals. The amplifier goes in muting for 3 seconds and this LED starts flashing until you turn off the amplifier.
REMOVE THE CAUSE OF OVERLOAD.
- 13 SPK: Speaker status LED.** It lights up when a speaker touches the car body. The amplifier goes in muting for 3 seconds and this LED starts flashing until you turn off the amplifier.
REMOVE THE CONTACT BETWEEN SPEAKER WIRE AND CAR BODY.

9. FRONT AND REAR PANELS

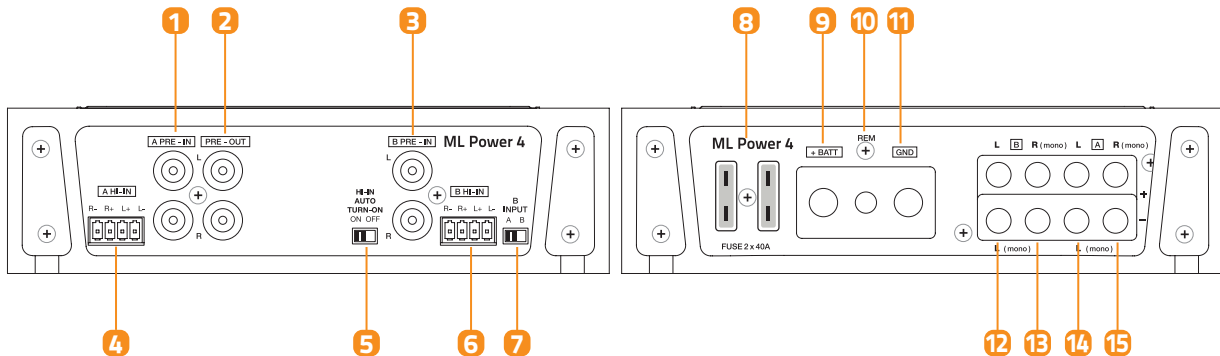

- 1 A PRE-IN:** Left and Right pre-amplified inputs to drive A channels. Connect to pre-amplified source output. Signal can be 0.2 to 5V RMS.
- 2 PRE-OUT:** This jack provides A channel Left and Right preamplified outputs to drive a separate amplifier (typical with subwoofer). These signals are full range, without crossover action.
- 3 B PRE-IN:** Left and Right pre-amplified inputs to drive B channels. Connect to preamplified source output. Signal can be 0.2 to 5V RMS.
- 4 A HI - IN:** Hi-Level signals Left and Right inputs for A channels. If the head unit does not feature a pre-amplified output, connect here its speaker wire to drive A Left and Right channels. Signal can be 0.8V to 20 V RMS.
- 5 HI - IN AUTO TURN-ON (ON - OFF):** Select **ON** to turn on the amplifier through the speaker power cable, if the source does not feature a 12V DC REMOTE OUT. Select **OFF** if REMOTE OUT from the source is available.
- 6 B HI - IN:** Hi-Level signals Left and Right inputs for B channels. If the head unit does not feature a pre-amplified output, connect here its speaker wire to drive B Left and Right channels. Signal can be 0.8V to 20 V RMS.
- 7 B INPUT (A - B):** Select **A** to drive B channels with A input signals. With this setup, do not connect B inputs. If the source features a REAR output, select **B** and connect its signals to B inputs (B PRE-IN or B HI-IN).
- 8 PROTECTION FUSE:** 2 x 40A.
- 9 POWER (+ BATT):** Terminal block for the amplifier **11±15V DC power supply positive pole connection**. Insert here the battery positive cable. The plug accepts cables up to 2 A.W.G.
- 10 REMOTE IN:** REMOTE IN terminal for the remote cable coming from the device which turns on the amplifier. Voltage must be between 7 and 16V DC.
- 11 POWER (GND):** Terminal block for the amplifier power supply **negative pole connection**. Insert here the battery negative cable or wire connected to the vehicle chassis. The plug accepts cables up to 2 A.W.G.
- 12 BL Speaker OUT:** B channel Left speaker + and - power terminal. For MONO (bridge) mode, connect the speaker negative terminal to BL- terminal.
- 13 BR Speaker OUT:** B channel Right speaker + and - power terminal. For MONO (bridge) mode, connect the speaker positive terminal to BR+ terminal.
- 14 AL Speaker OUT:** A channel Left speaker + and - power terminal. For MONO (bridge) mode, connect the speaker negative terminal to AL- terminal.
- 15 AR Speaker OUT:** A channel Right speaker + and - power terminal. For MONO (bridge) mode, connect the speaker positive terminal to AR+ terminal.

10. CONFIGURATION DIAGRAMS

PRE-IN A FOR WOOFER AND MID/HI

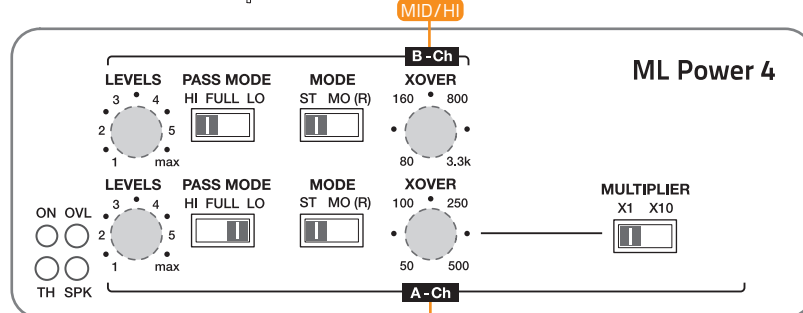
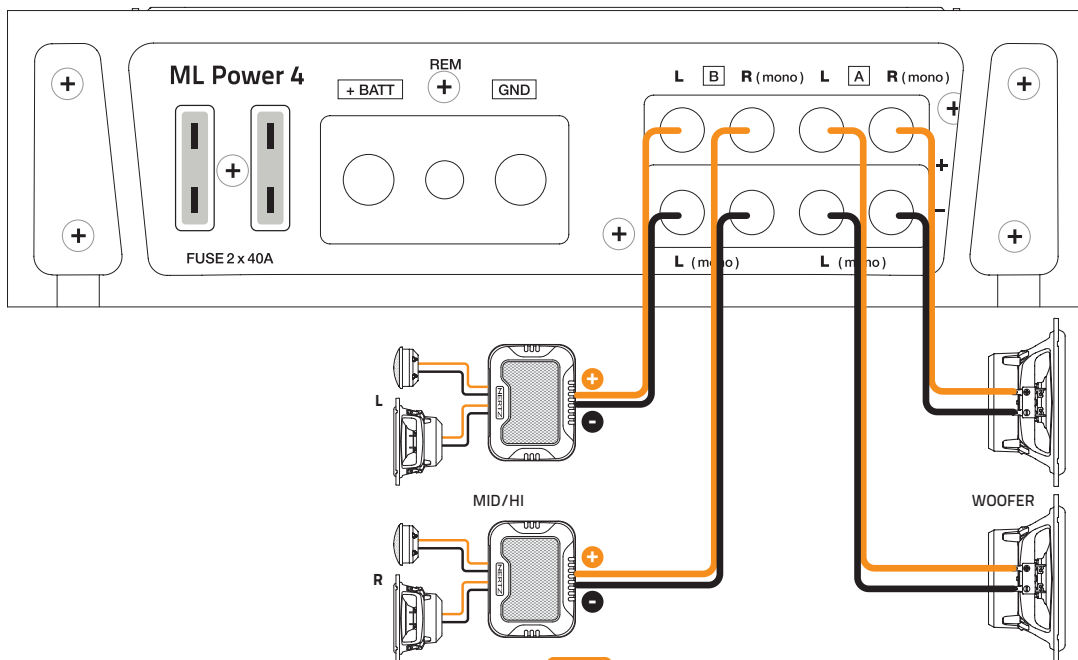
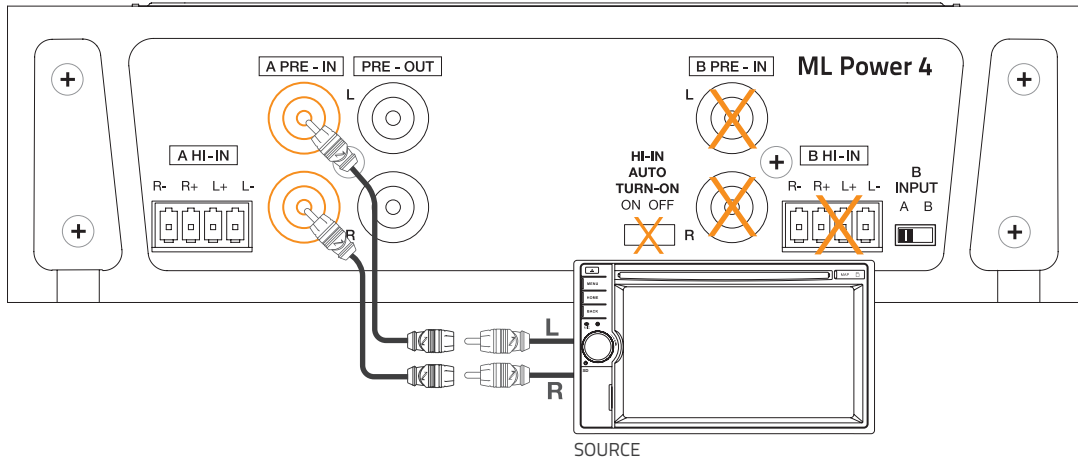

PRE-IN A / B FOR FRONT AND REAR

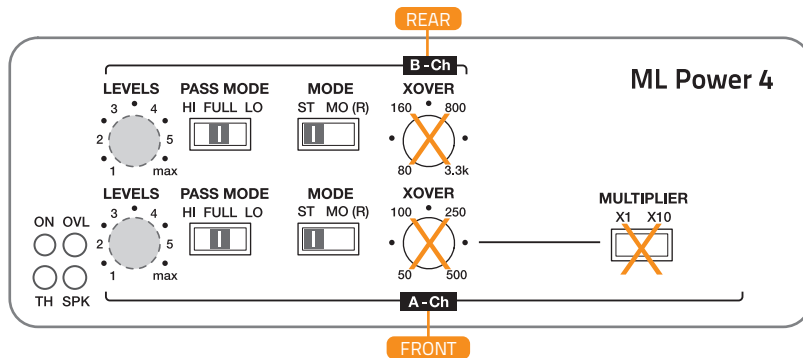
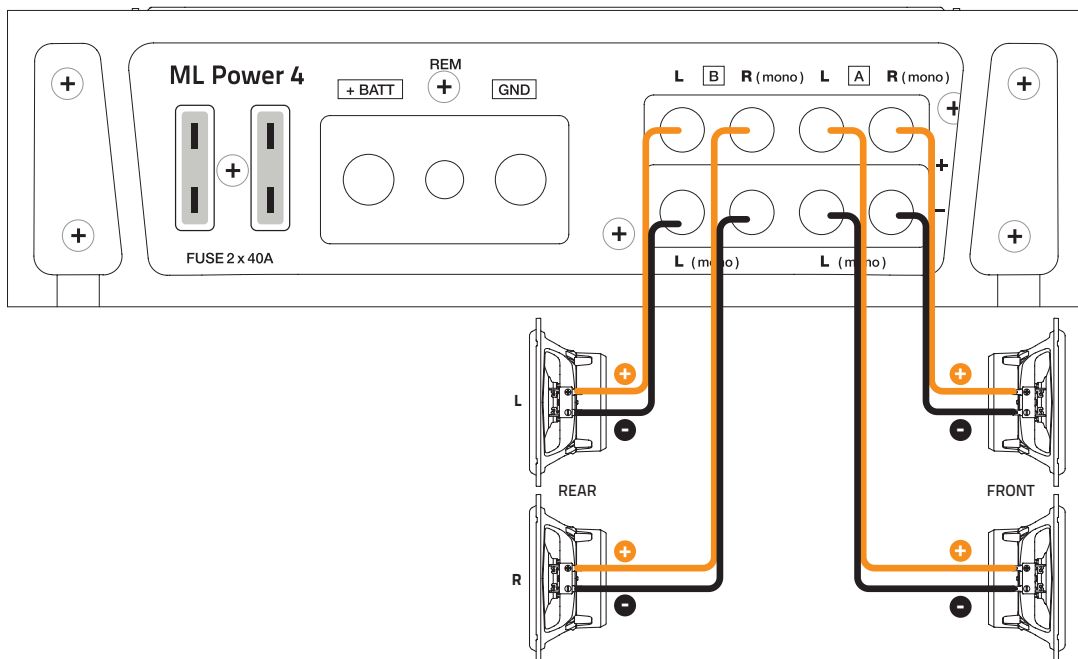
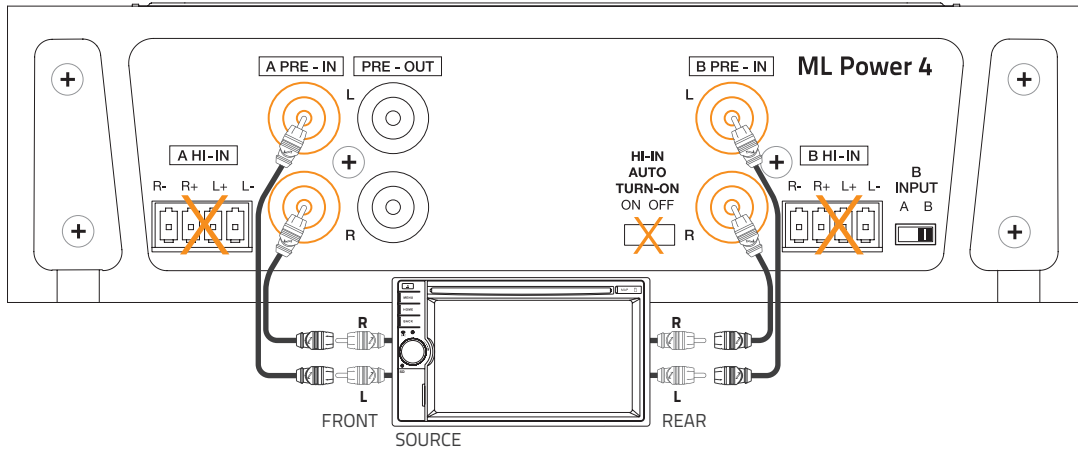

PRE-IN A AND HI-IN B FOR FRONT AND REAR

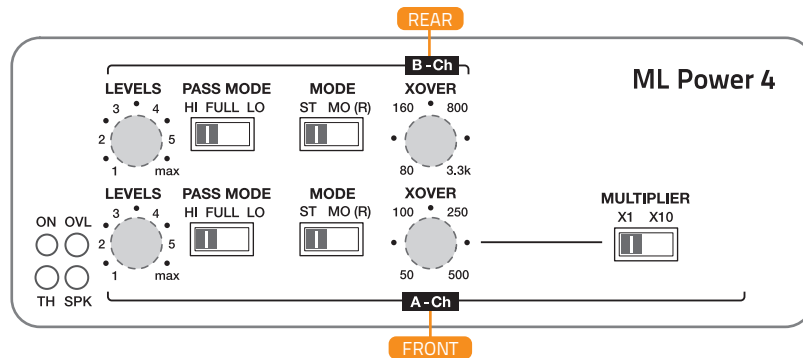
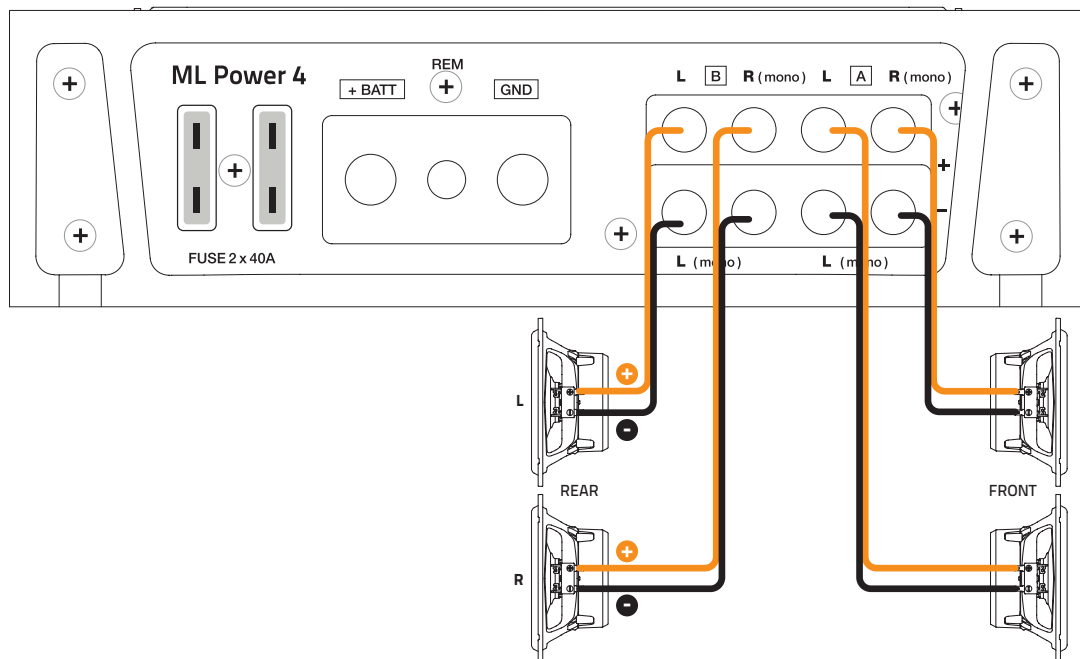
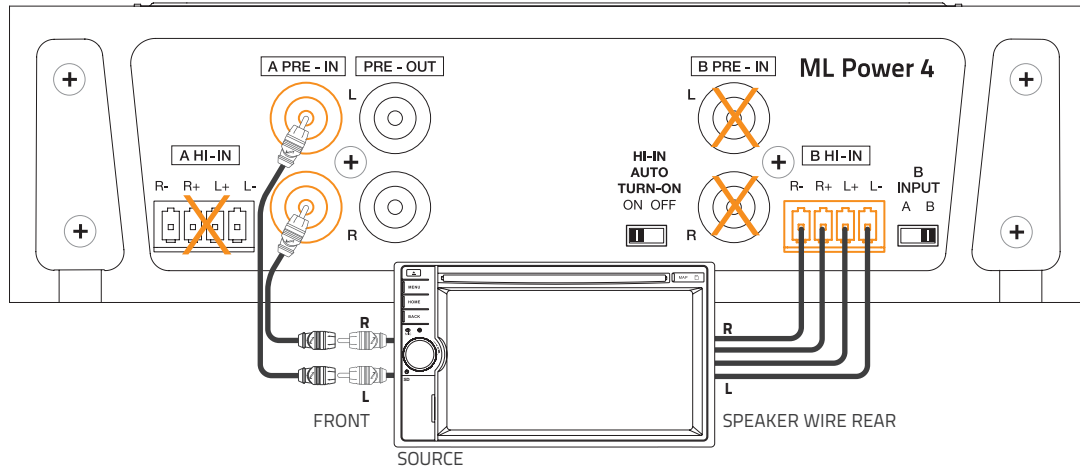

HI-IN A AND PRE-OUT

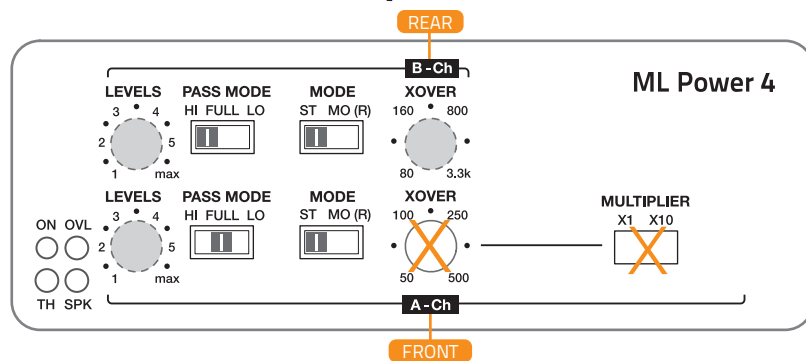
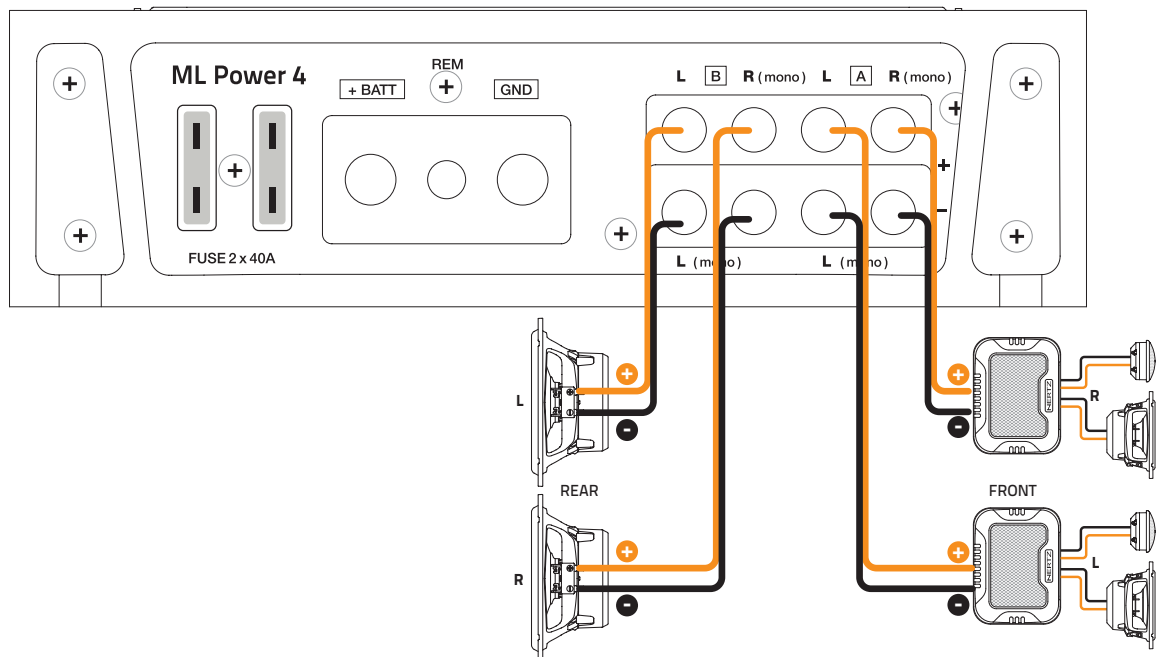
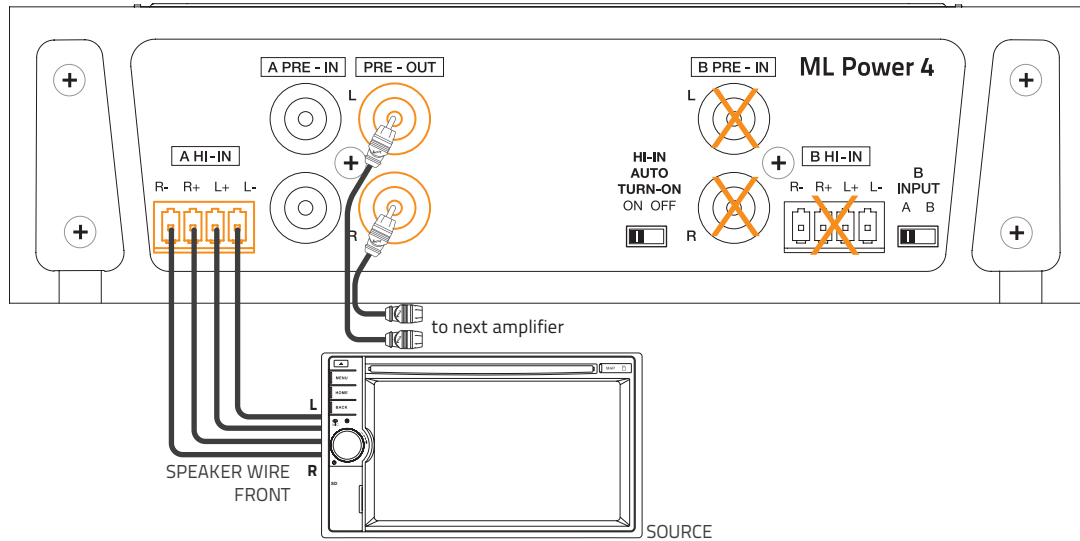

HI-IN A + B AND PRE-OUT

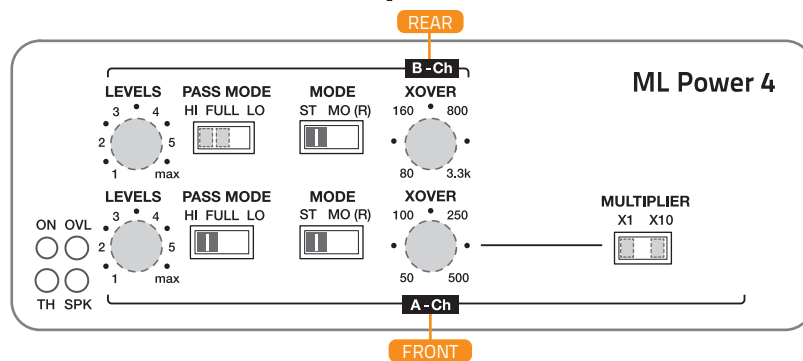
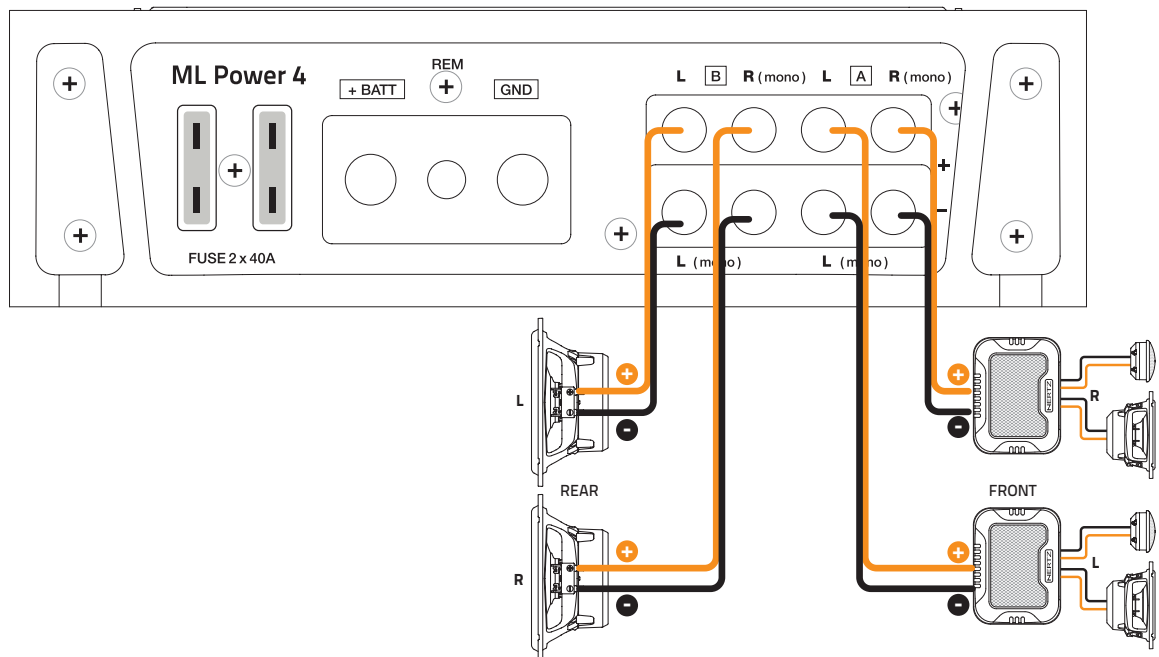
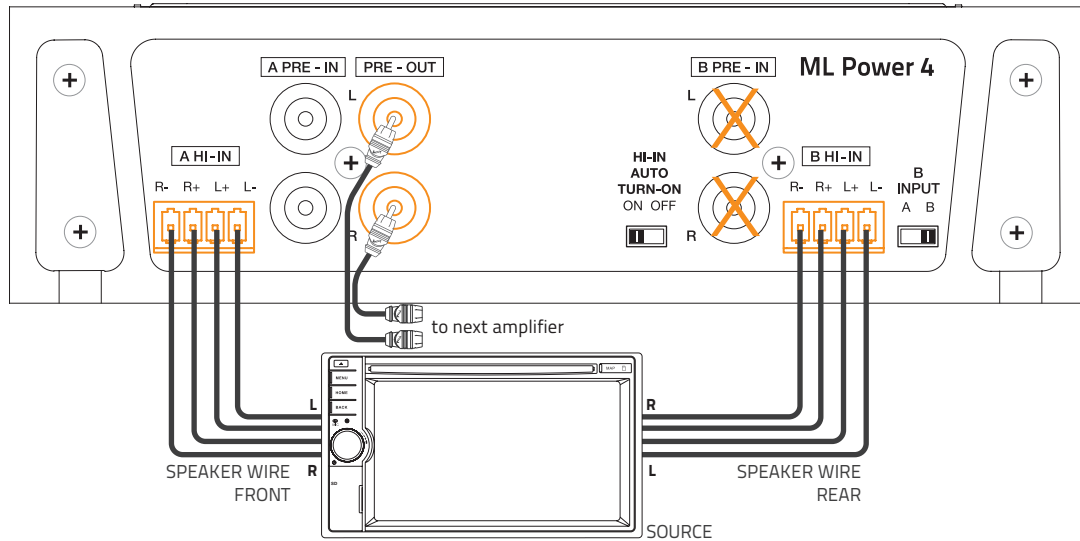

HI-IN A + B FOR FRONT AND REAR

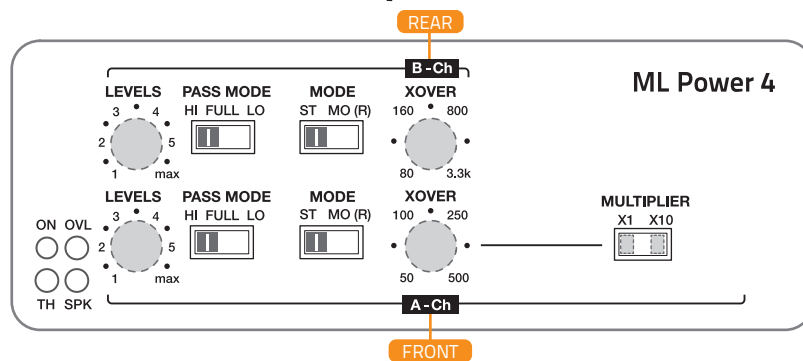
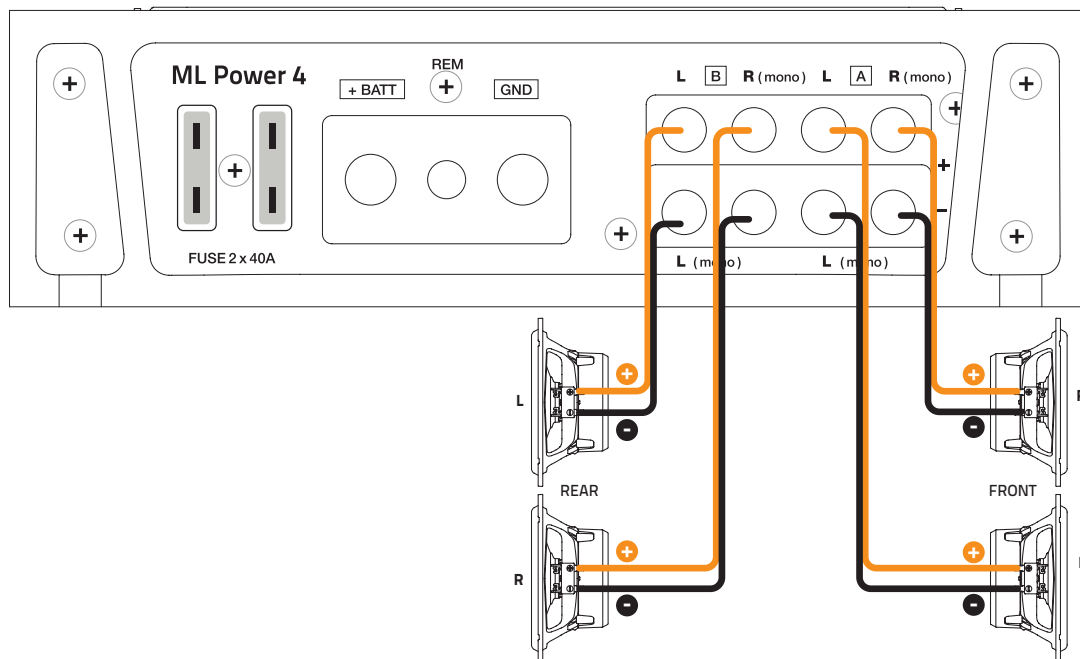
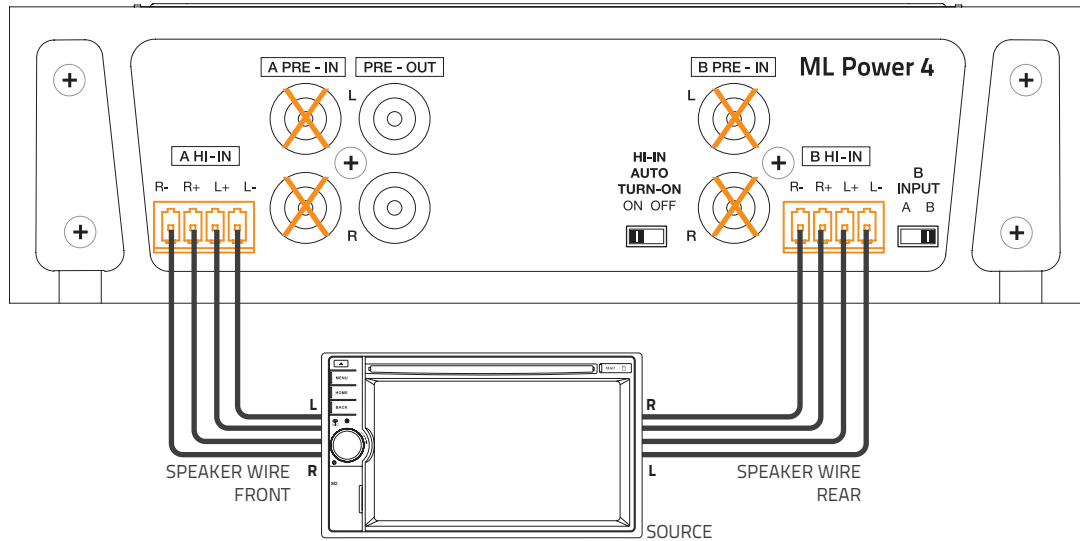

PRE-IN A FOR FRONT AND SUBWOOFER MONO (BRIDGE)

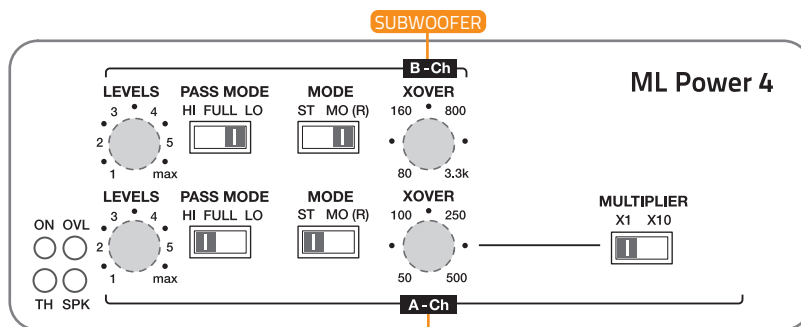
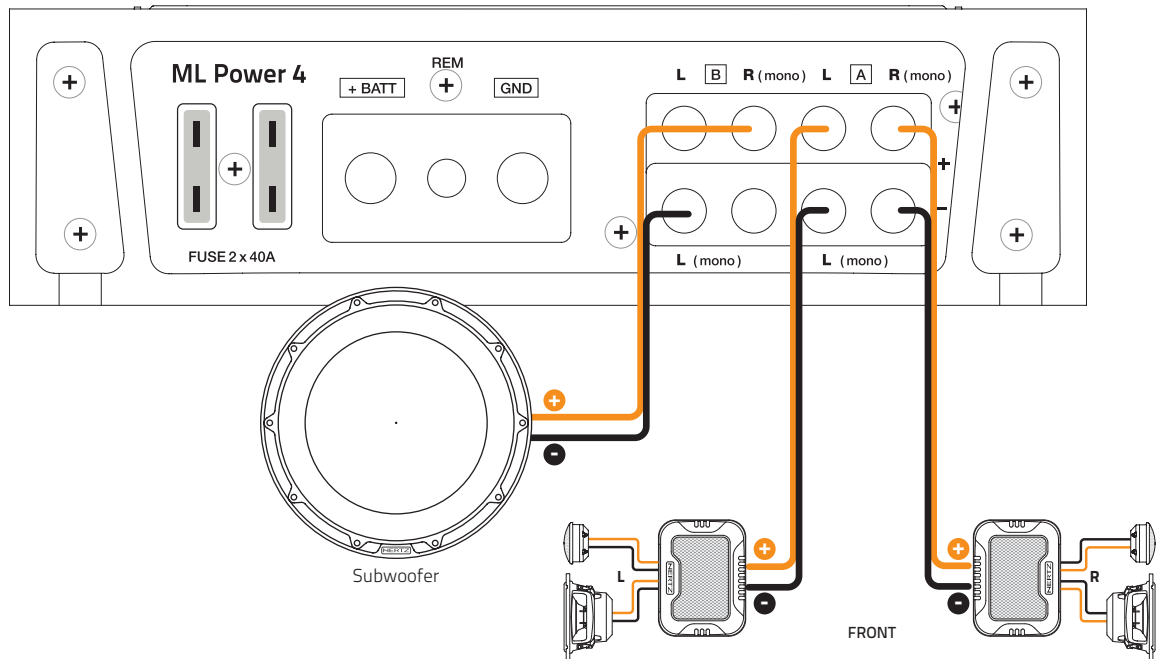
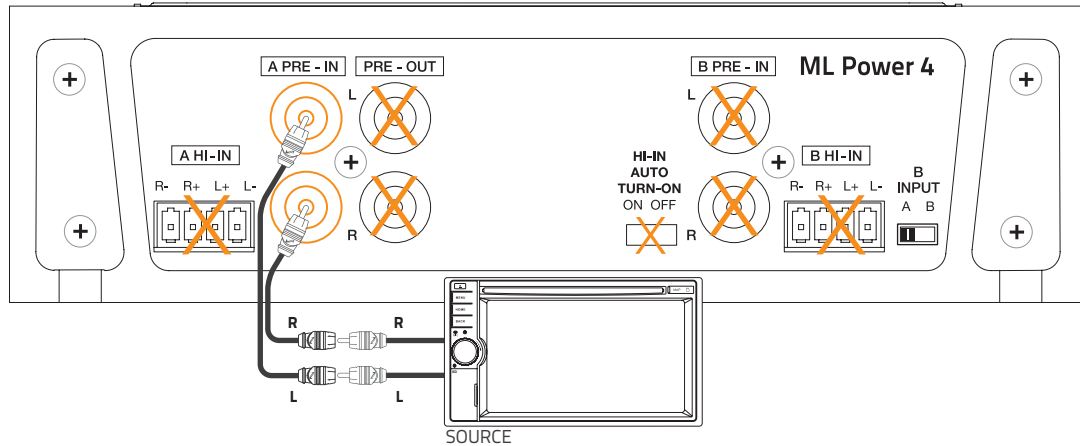

PRE-IN A + B FOR FRONT DUAL MONO (BRIDGE)

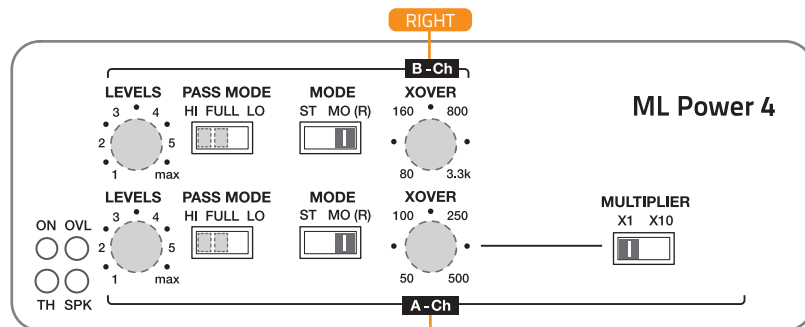
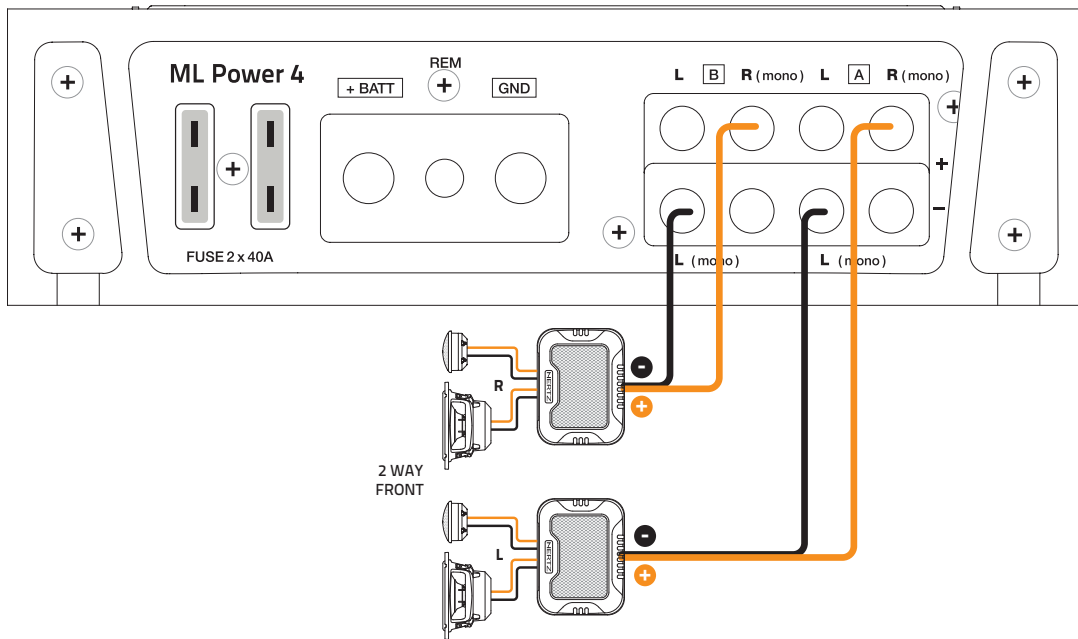
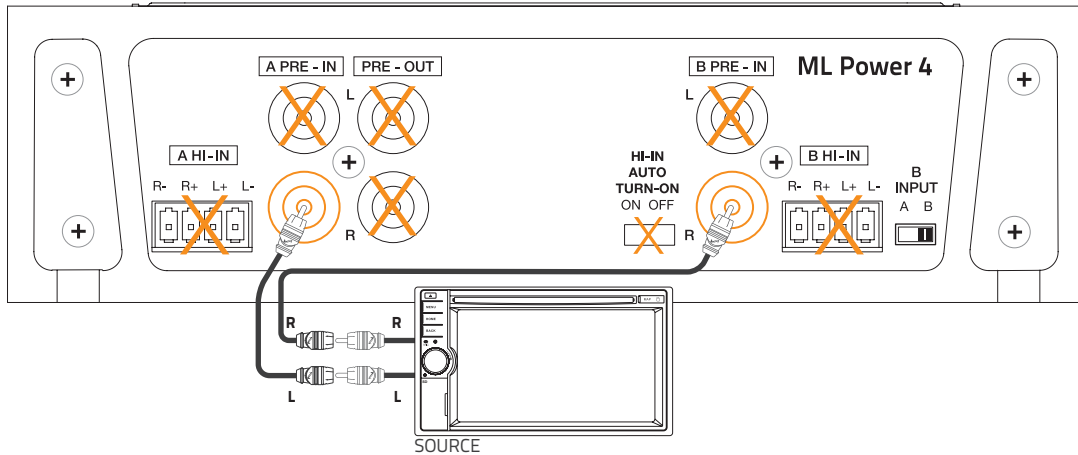

Note: select same XOVER frequency for A ch and B ch

HI-IN A AND PRE-OUT FOR WOOFER AND MID/HI

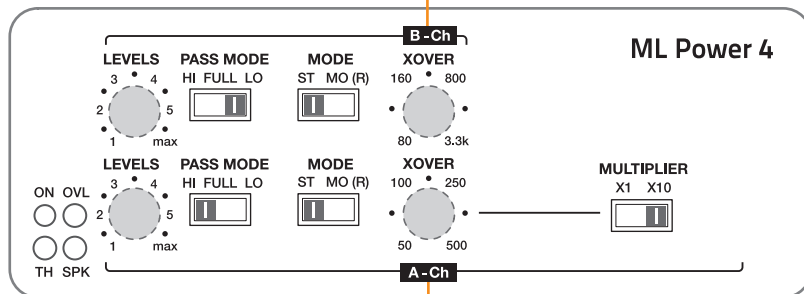
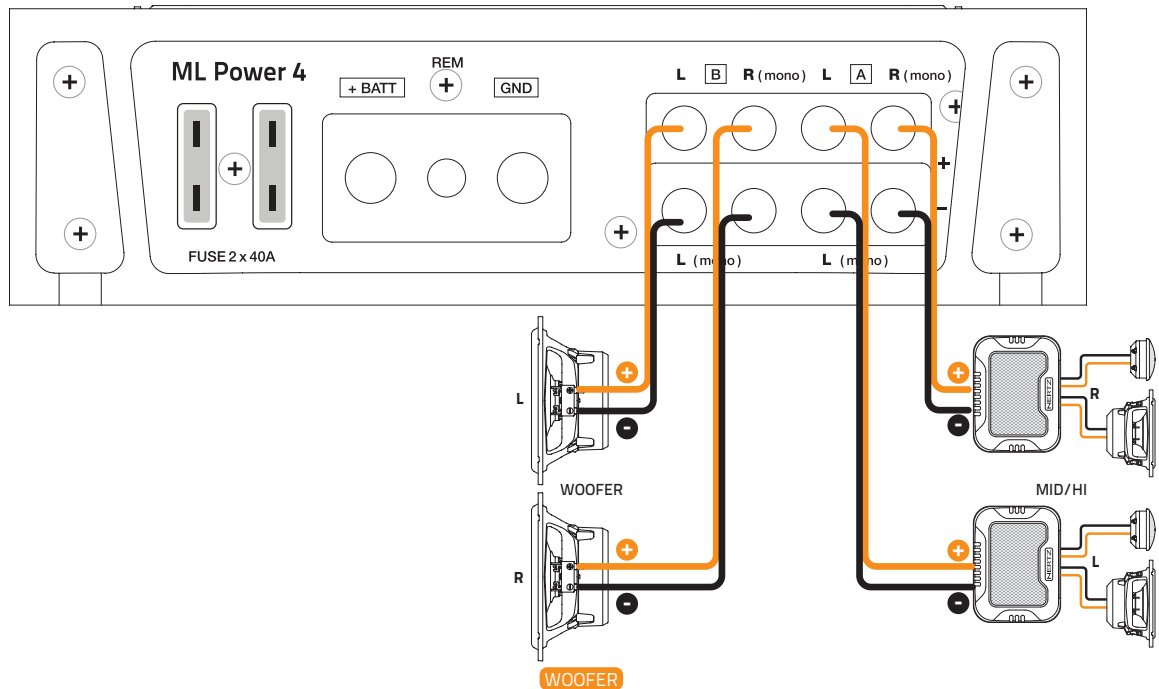
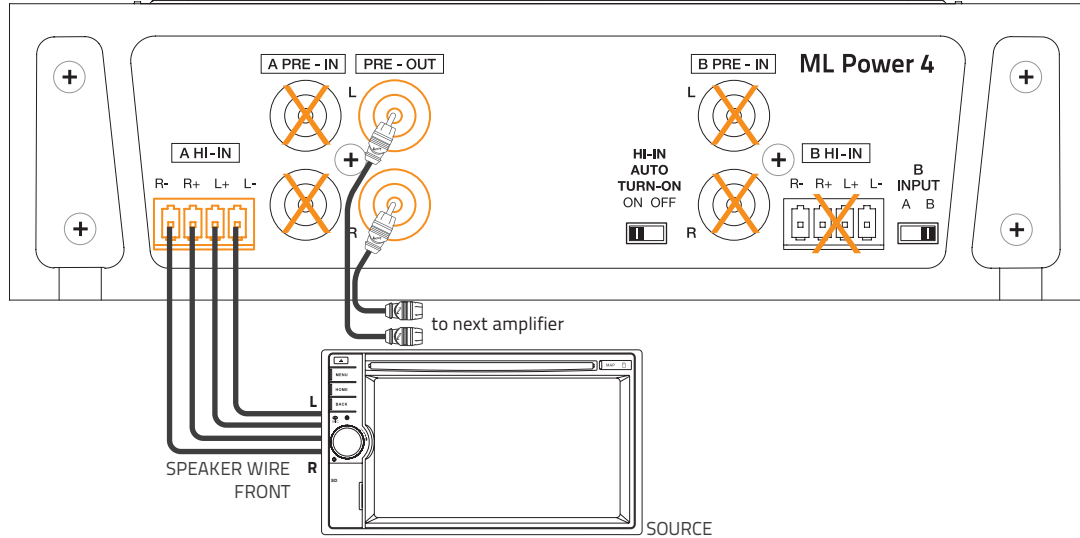

X N. A.
 Selected function
 Adjustment controls
 System Start-up

Note: select same XOVER frequency for A ch and B ch

11. CABLES

Connection cables

For maximum performance, always use new, good quality cables; their outer jacket must not be spoiled, and the copper must not show oxidation. For proper operation, always consider the length of the connection, the load and the current it has to handle. Connection products are the most flexible and complete; they are designed and built in order to get the best out of every installation, especially when used with Hertz amplifiers.

Speaker cable recommendations

The table refers to continuous power into 4 Ω load. If load decreases, cable size will have to increase proportionally.

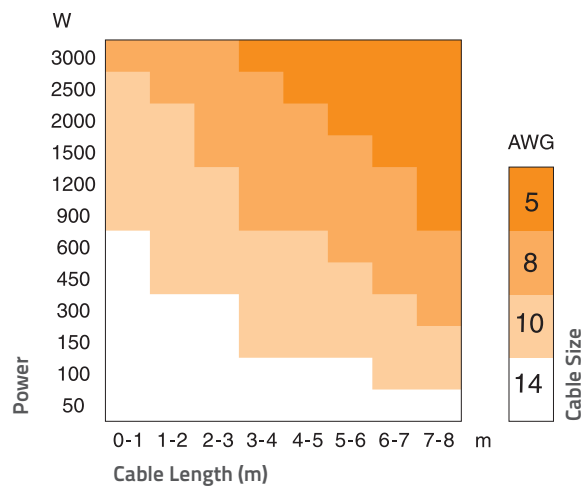

Power and Ground cable recommendations

If you don't know your system current consumption, find it using the mathematical formula below and find this same value on the left hand column of the table. Then calculate the length of your connection and find this same value on the bottom column of the table. At the point where these two values cross is the minimum section in gauge (A.W.G.) which Connection recommends for building a high performance, reliable system.

How to calculate your system current consumption

$$I = \frac{TP \times 2}{V_{batt}}$$

I = Current consumption of your system in ampere (A);

TP = Total power (RMS) of channels of all amplifiers in your system;

V_{batt} = Usually value is 12 V, the nominal automotive electrical system voltage.

Example:

- Your total system power (RMS) of all channels in all amplifiers is a combined 650 W.
- Your amplifier average is 50% efficiency, as most amplifiers today.
- Your electrical system is 12 V.

$$I = \frac{650 \times 2}{12} = 108,3 \text{ A Current consumption}$$

Power & Ground cable calculation table		Cable Size	
Minimum gauge size recommended for MAINPOWER & POWER FLOW cables. MAINPOWER cables ensure higher instantaneous current transfer.		A.W.G.	mm ²
240-350		1/0	53,5
180-240		2	33,6
150-180		4	21,2
120-150		8	8,4
100-120		10	5,3
80-100		12	3,3
60-80		14	2,1
40-60		16	1,3
20-40		18	0,8
8-20			
0-8			
	0-1 1-2 2-3 3-4 4-5 5-6 6-7 7-8		

12. BLOCK DIAGRAM

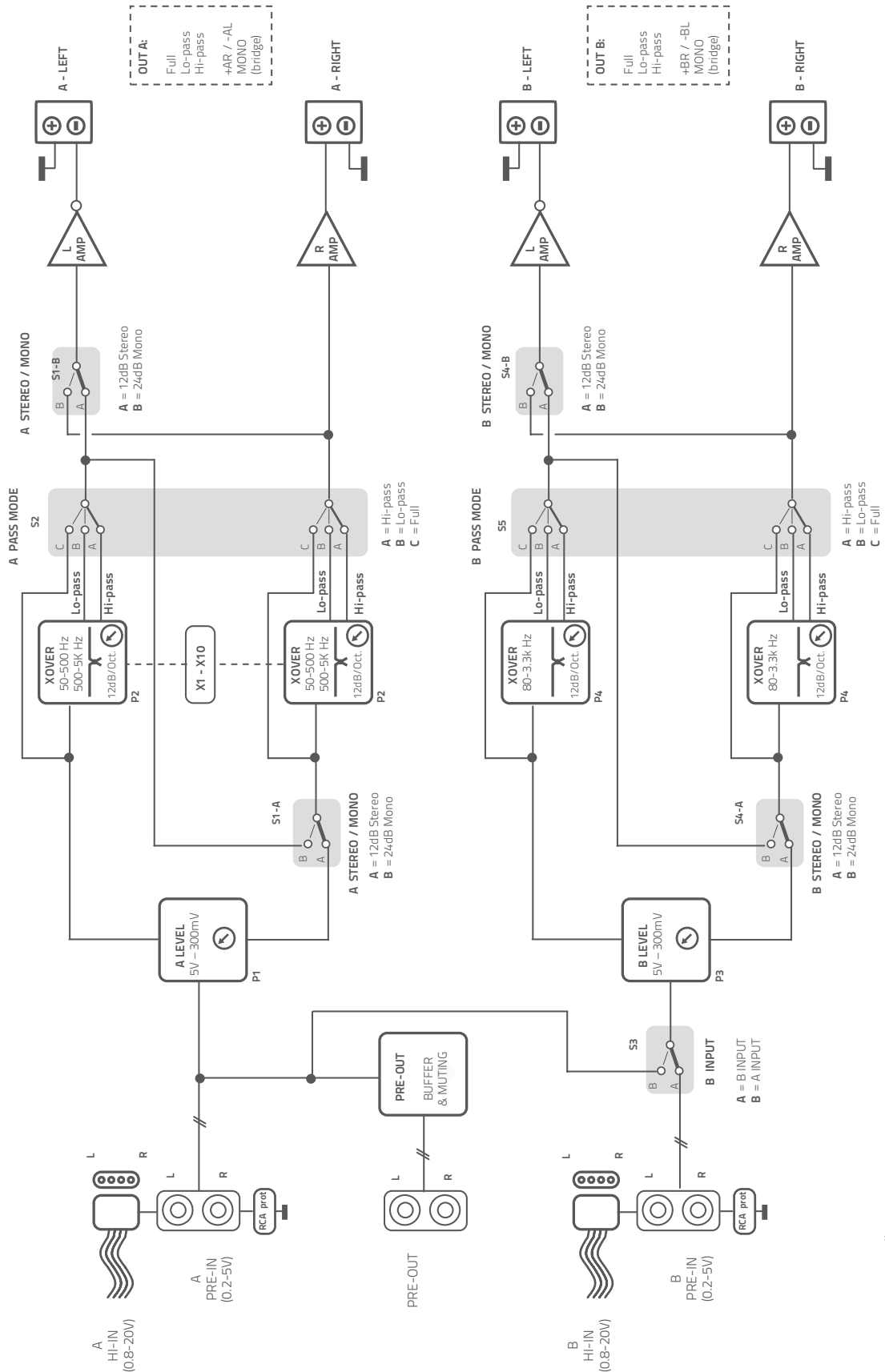

STEREO SIGNALS

13. TECHNICAL SPECIFICATIONS

Power Supply	
Power supply voltage / fuse:	11±15 VDC
Idling current:	1,5 A
Idling current when OFF:	0,04 mA
Consumption @ 2Ω, 14.4 VDC (Max Musical Power):	50 A
Remote In:	4 ÷ 15 VDC - 1 mA
ART™:	Automatic Remote Turn-On/Off with Speaker-In
Fuse:	2 x 40 A

Amplifier Stage	
Distorsion - THD (100 Hz @ 4Ω):	0,08 %
Bandwidth (-3 dB):	5 ÷ 55k Hz
S/N Ratio (A weighted @ 1 V):	100 dB
Damping factor (100 Hz @ 4Ω):	80
Pre-In sensitivity:	0,2 ÷ 5 V RMS
Pre-In impedance:	15 kΩ
Speaker-In sensitivity:	0,8 ÷ 20 V RMS
Speaker-In impedance:	470 Ω
Load impedance:	
4 Ch:	2Ω
4 Ch:	2 x 2Ω ÷ 1 x 4Ω
2 Ch:	4Ω
Output Power (RMS) @ 14.4 VDC, THD 1%:	
4 Ch:	150 W x 4 (4Ω)
4 Ch:	250 W x 4 (2Ω)
3 Ch:	150 W x 2 (4Ω) + 500 W x 1 (4Ω)
3 Ch:	250 W x 2 (2Ω) + 500 W x 1 (4Ω)
2 Ch:	500 W x 2 (4Ω)
CEA 2006-A Ratings:	
RMS Power (4Ω, ≤1 %THD+N, 14.4 V):	120 W x 4 Ch
S/N Ratio (ref. 1 W output):	80 dBA



Inputs / Outputs / Filter	
INPUTS:	PRE IN / SPEAKER IN
OUTPUTS:	Pre OUT
A Ch Filters: Full/Hi-Pass/Lo-Pass:	50 ÷ 5k Hz (2 range) @ 12 dB/Oct.
B Ch Filters: Full/Hi-Pass/Lo-Pass:	80 ÷ 3.3k Hz @ 12 dB/Oct.

Size / Weight	
Max size (mm / in.):	289 x 170 x 46,7 / 11.38 x 6.69 x 1.84
Weight (kg / lb.):	2,45 / 5.4



Technology Air-Sound
Manufactured by
elettromedia Italy

All Specifications Subject to Change Without Notice

HERTZ

PART OF **ELETTROMEDIA** - 62018 Potenza Picena (MC) Italy - T +39 0733 870 870 - F +39 0733 870 880 - www.elettromedia.it